

SINGER

61W30

PRICE LIST

OF

PARTS



MACHINE No. 61w30

THE SINGER MANUFACTURING COMPANY

INDEX

	PAGE
ACCESSORIES.....	14
BOBBIN WINDER.....	14
FEED DOGS.....	16
KNEE LIFTER PARTS.....	15
MACHINE No. 61w30.....	7
NUMERICAL LIST OF PARTS.....	19
PRESSER FEET.....	16
ROLLER PRESSERS.....	17
THROAT PLATES.....	18

From the library of: Diamond Needle Corp

Instructions for Ordering

In ordering from this list, use **ONLY** the **PART** number in the **FIRST** column.

The number stamped on a Sewing Machine Part is the number of the Single Part only, except when the part includes Set Screws, Clamping Screws, Studs and Rollers Spun on, Small Wires riveted, or Parts soldered together, etc., which it is necessary to furnish in combination.

Every combination of parts sent out has its specific number which, although not stamped on Parts (except in above cases) must be used when ordering the combination.

Each number always indicates the **SAME PART** in whatever list it appears, or for whatever Machine.

The letters after some of the numbers indicate the style of finish only, as follows:

- A. Hardened, Polished and Plated.
- B. Polished and Plated.
- C. Hardened only.
- D. Polished only.
- E. Soft, not polished.
- F. Hardened and Polished.
- H. Blued.

These letters **MUST BE USED** when they appear in the list and **AFTER** the number, as in the list.

In this series

200001 to 201500 are Screw Numbers.

201501 to 201800 are Nut Numbers.

201801 to 202000 are Roller Numbers.

202001 and upward are numbers of Machine Parts.

The figures in the second column refer only to the plate in which the illustration of the part is shown and are **NOT TO BE USED** in ordering.

Two or more numbers over a cut indicate that the difference between such parts is not visible in an illustration.

Parts marked with an asterisk (*) are furnished only when repairs are made at the factory.

LIST OF PARTS COMPLETE

FOR

MACHINE No. 61w30

For Leather. Has Roller Presser

No.	Plate	Name	Each
*202242	---	Arm	\$ ---
*203170	---	" 202242 and Bed 202532 with two 204235, three each 200010e and 202005	---
202247	10667	Arm Cap	35
200278u	10244	" " Screw	05
202248u	10244	" " " Washer	05
204235	10668	" Position Pin	02
200010e	10245	" Screw	06
202005	10245	" " Washer	01
202249	13351	" Shaft with 200357e and 203100	1 50
202243	13351	" " Bushing (back) with 202244	75
202244	---	" " " Oil Packing (wick)	02
200338c	10244	Arm Shaft Bushing (back) Set Screw	04
202245	10667	" " " (front) with 202236 and 202260	55
202260	---	Arm Shaft Bushing (front) Oil Packing (wick)	01
200502u	10246	Arm Shaft Bushing (front) Oil Packing Thumb Screw	25
202036	10668	Arm Shaft Bushing (front) Position Pin	01
200338c	10244	" " " " Set Screw	04
202530	13351	" " Connection Belt	60
202252	10244	" " " " Pulley with 200327e, 200602e and two 202253	1 00
200602e	10244	Arm Shaft Connection Belt Pulley Position Screw	10
200327e	10244	Arm Shaft Connection Belt Pulley Set Screw	04
202253	10244	Arm Shaft Connection Belt Pulley Spring Flange	15
203100	---	Arm Shaft Oil Packing (wick)	01
200357e	10244	" " " " Stop Screw	03
202255	13351	Balance Wheel with 200328c and 200335c	85
200328c	10244	" " Position Screw	04
200335c	10244	" " Set Screw	04
*202532	---	Bed with 202872	---
202258	12153	" Hinge Connection (2)	08

From the library of Raymond Needle Co.

Parts for Machine No. 61w30

No.	Plate	Name	Each
200141F	10248	Roller Presser Arm Bracket Spring Stop Screw	\$ 02
200096D	13361	Roller Presser Arm Screw	03
202557	10920	" " Bar	80
200548F	13361	" " Hinge Screw	10
201534H	13361	" " " " Nut	03
202840	10920	Roller Presser and Bar complete, Nos. 200675c, 202557 to 202559, 206887 and two 200141F	2 15
202068	12153	Spool Holder Base	15
200575H	10668	" " " Screw	05
204296	12153	" " Wire	10
200079H	10668	" " " Hinge Screw	02
204297	12153	Spool Holder complete, Nos. 200079H, 202068 and 204296	25
202397	10668	Take-up (auxiliary)	15
200842E	10668	" " " Screw	10
202398	10247	" Lever	1 20
202399	10247	" " Driving Stud with 202277 ..	25
202277	—	" " " " Oil Packing (wick)	01
202400	10247	Take-up Lever Hinge Stud with 202423 ..	25
202423	—	" " " " Oil Packing (wick)	01
200383c	10246	Take-up Lever Hinge Stud Set Screw ..	02
202401	10247	" " Oiling Felt	02
200132E	10247	" " " " Screw	02
202402	10247	Tension Disc (back)	05
202403	10247	" " (front)	10
202404	10247	" Release Plunger	05
202405	10247	" " Washer	15
202407	10247	" Spring	05
200625F	10247	" Stud with 204925	15
200081c	10247	" " Set Screw	02
204925	10668	" " Washer	01
201572B	13361	" Thumb Nut	04
202409	10252	Tension complete, Nos. 200625E, 201572B, 202402, 202403, 202405, 202407 and 202410	55
202410	10252	Thread Controller Spring	03
202411	10252	" " " Stop	10
200132E	10247	" " " " Screw ..	02
202413	10252	" Guide	05
202414	10252	" "	03
202415	10252	" "	10
202417	10252	" "	02
200582H	10252	" " Screw	02
200355H	10272	" " Set Screw	03

Parts for Machine No. 61w30

No.	Plate	Name	Each
200368H	10668	Thread Guide Set Screw	\$ 02
202091	10252	" Retainer Sleeve	05
202092	10252	" " Spring	01
204058B	10252	" " Stud	07
200368H	10668	" " " Set Screw	02
204059	10668	Thread Retainer complete, Nos. 202091, 202092 and 204058B	15
202820	13362	Throat Plate, 50 needle hole, for needle sizes 14 and 15, with 202534, 202619 and two 200583H	75
202534	10668	Throat Plate Bobbin Case Stop	25
202619	10668	" " " " " Position Pin	Per 100 25
200583H	10668	Throat Plate Bobbin Case Stop Screw ..	02
202872	10668	" " Position Pin	Per 100 25
200577H	10245	" " Screw (2)	02

THROAT PLATES

No.	Plate	Name	Each
202819	13362	Throat Plate, 50 needle hole, for needle sizes 14 and 15, with 202534, 202619 and two 200583ir, for 202283, 207051 and 207052	\$ 75
202820	13362	Throat Plate, 50 needle hole, for needle sizes 14 and 15, with 202534, 202619 and two 200583ir, for 202285, 202813 and 203138	75
206798	13362	Throat Plate, 46 needle hole, for needle sizes 16 and 18, with 202534, 202619 and two 200583ir, for 202285, 202813 and 203138	75

PLATE 10244-FULL SIZE

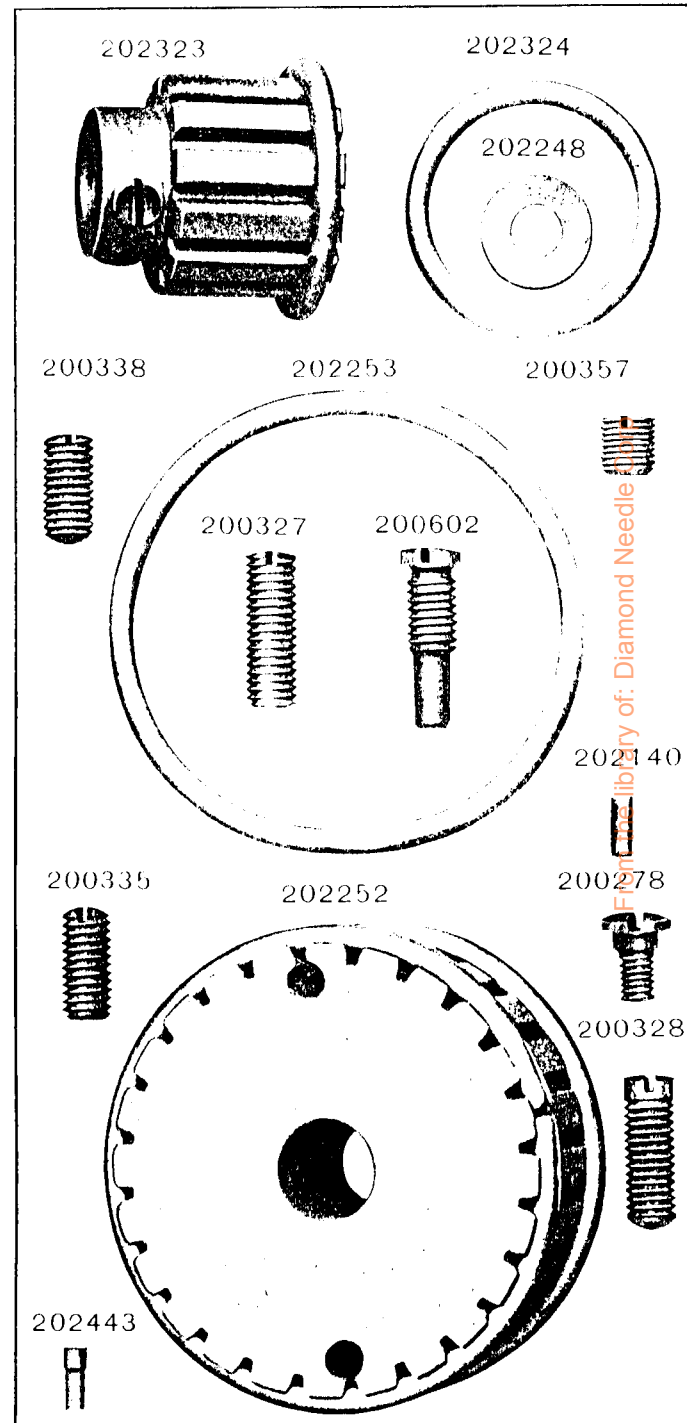

PLATE 10245-FULL SIZE

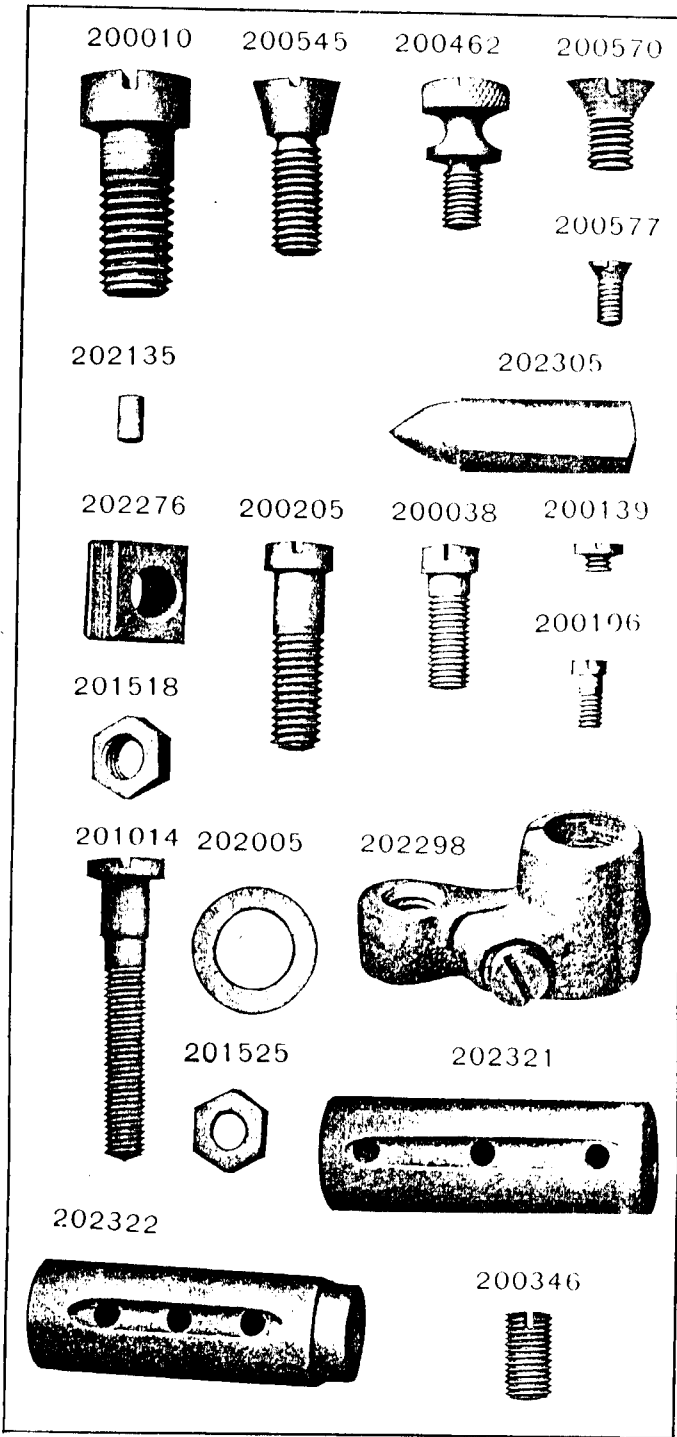
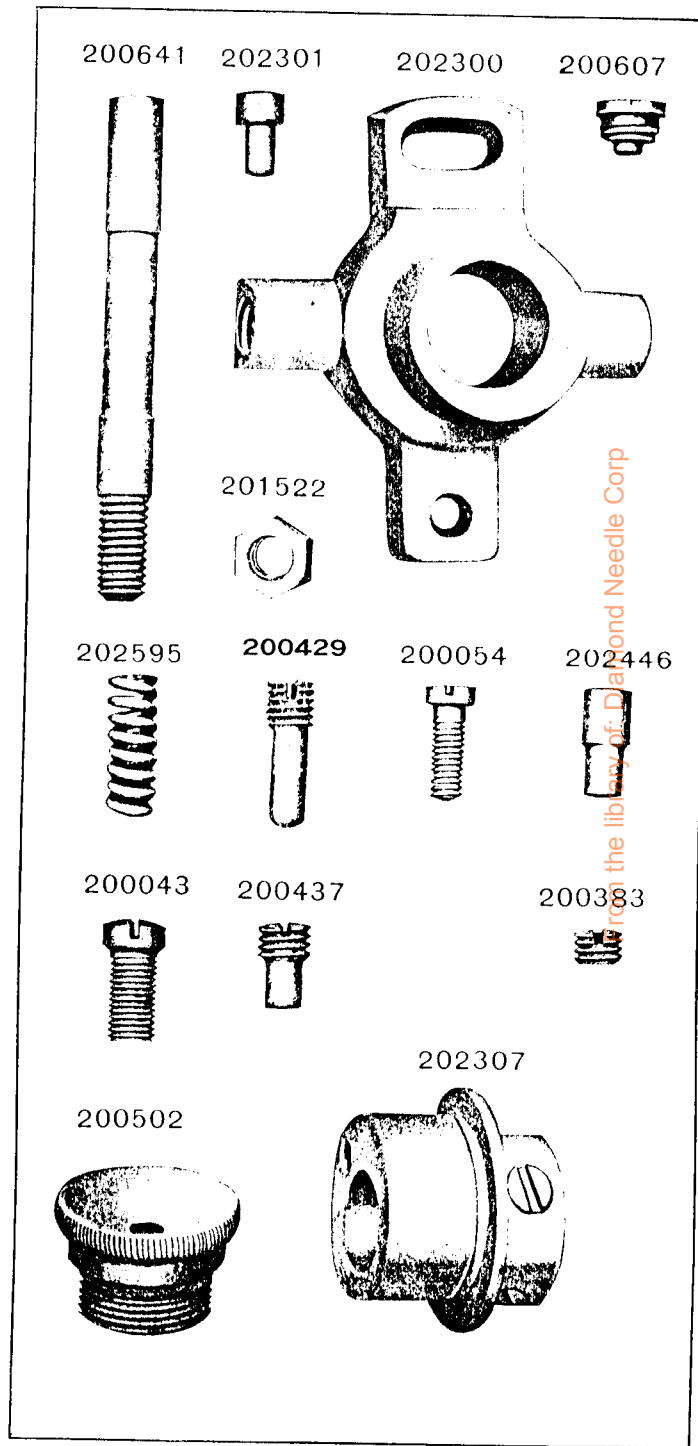

PLATE 10246-FULL SIZE



from the library of Diamond Needle Corp

PLATE 10247—FULL SIZE

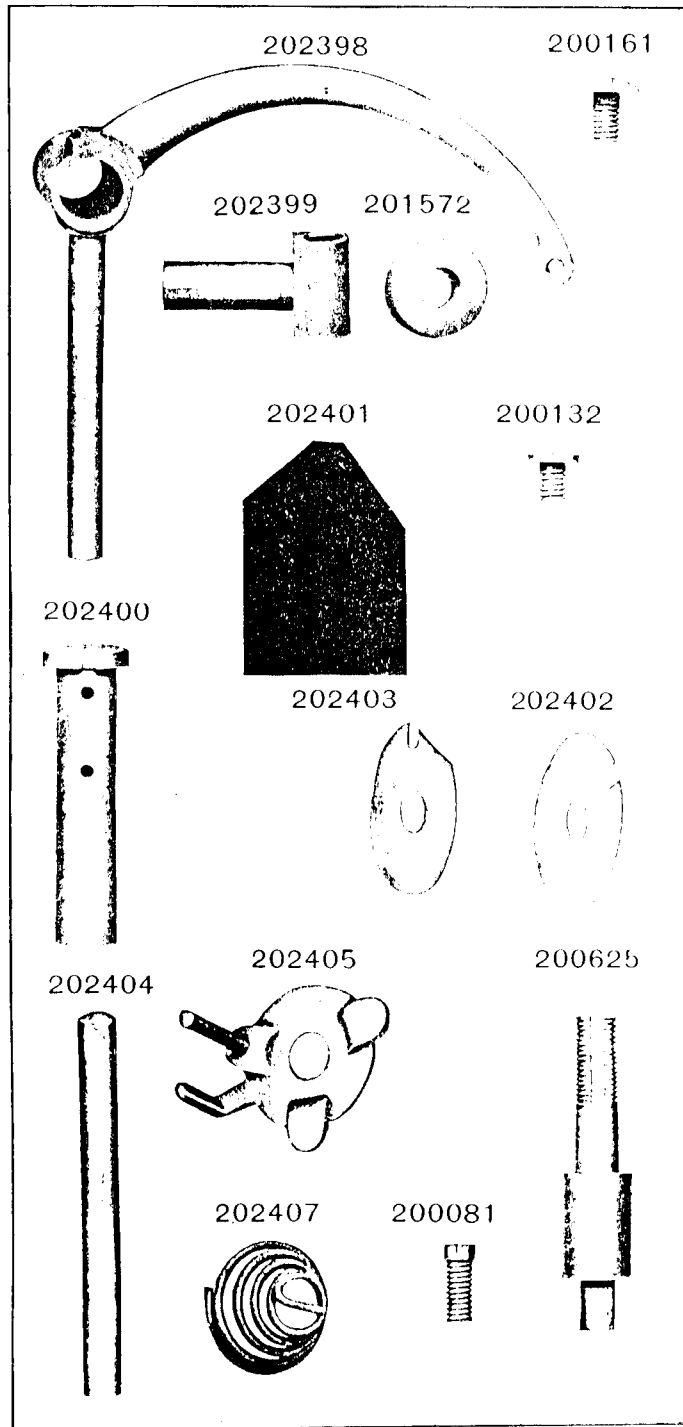
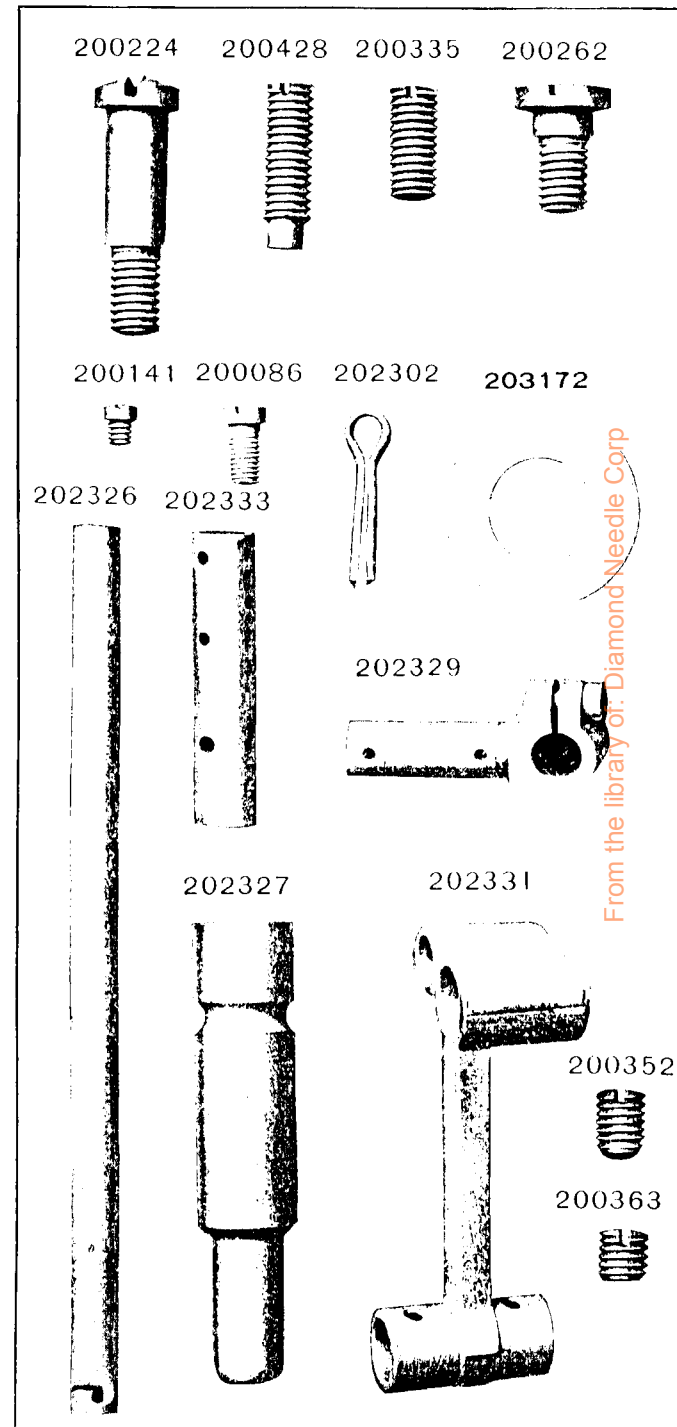

PLATE 10248—FULL SIZE



From the library of: Diamond Needle Corp

PLATE 10249—FULL SIZE

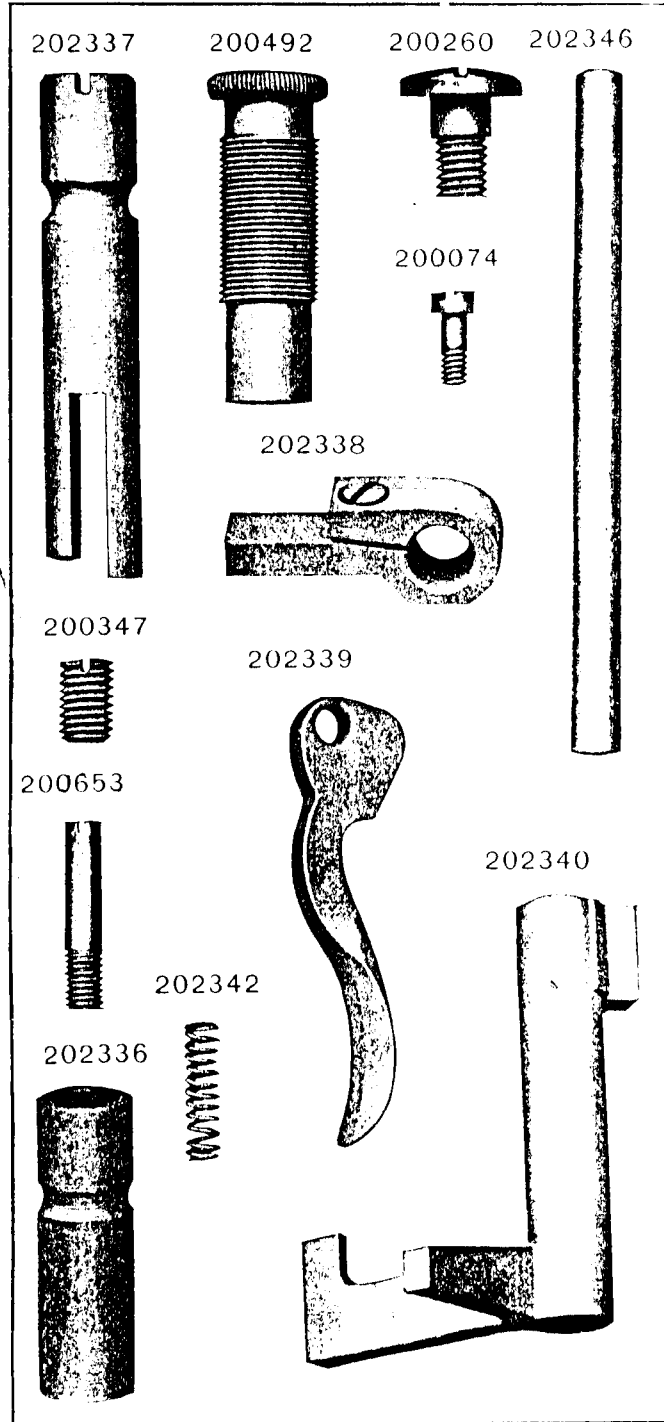

PLATE 10252—FULL SIZE

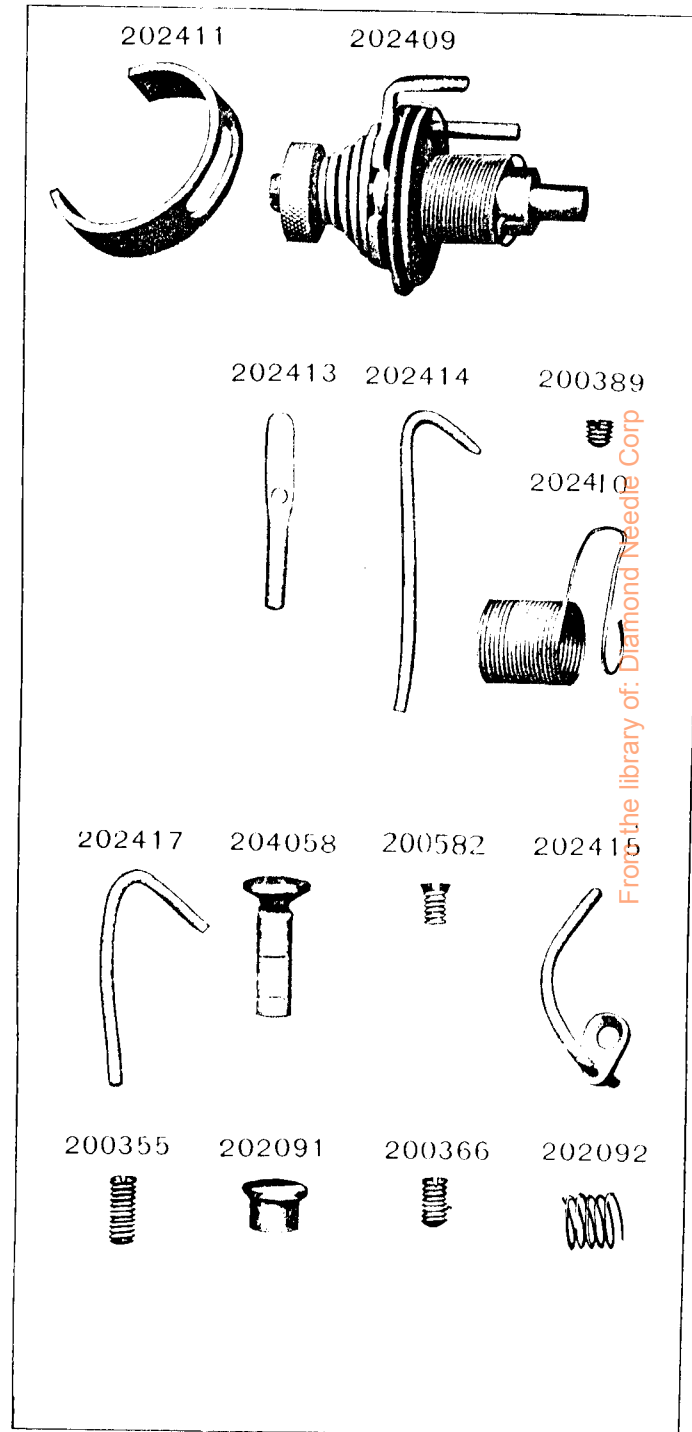

PLATE 10271—ONE-HALF SIZE

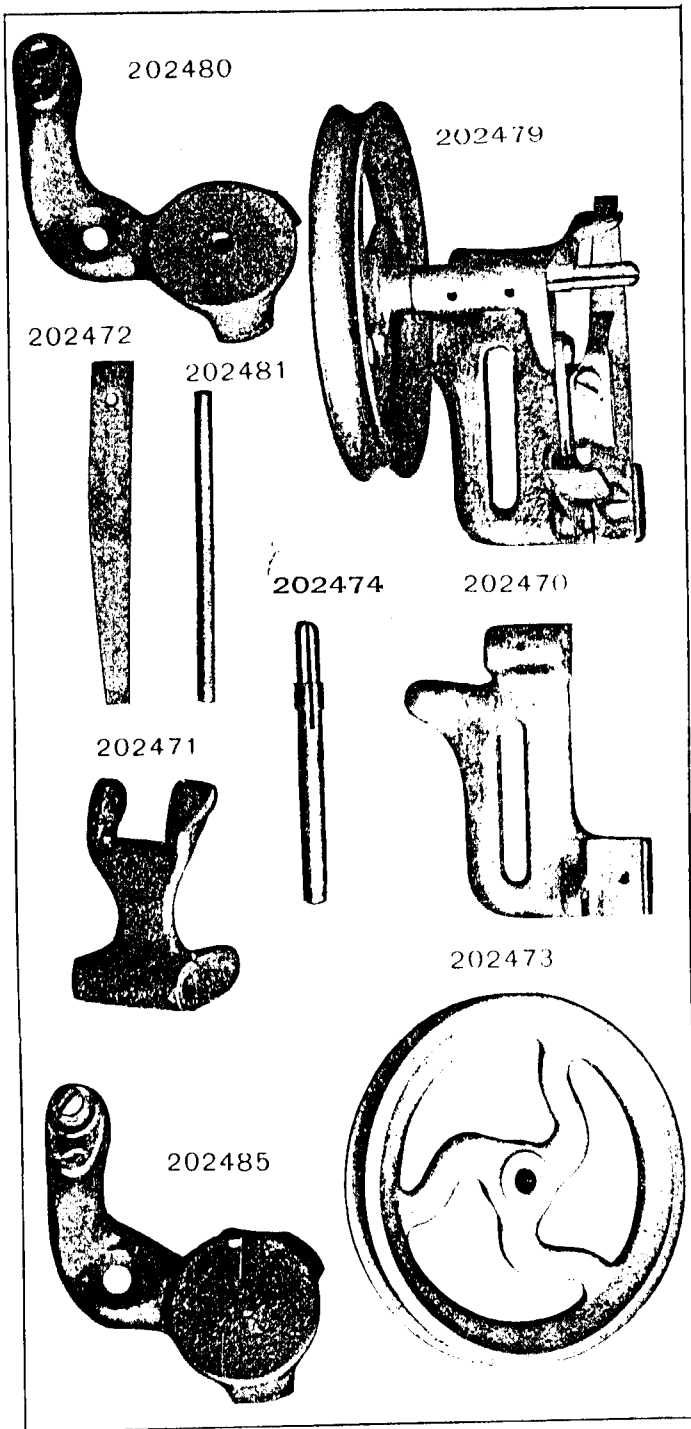

PLATE 10272—FULL SIZE

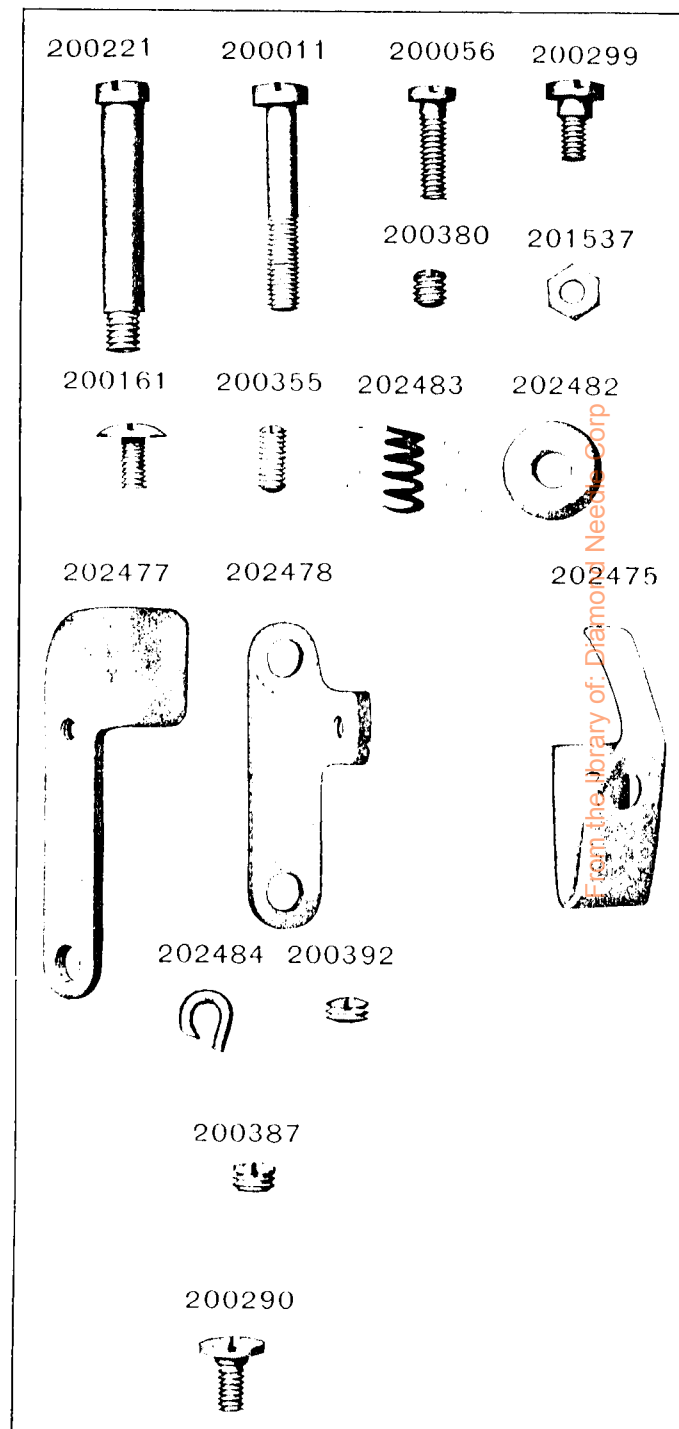

PLATE 10667 - ONE - HALF SIZE

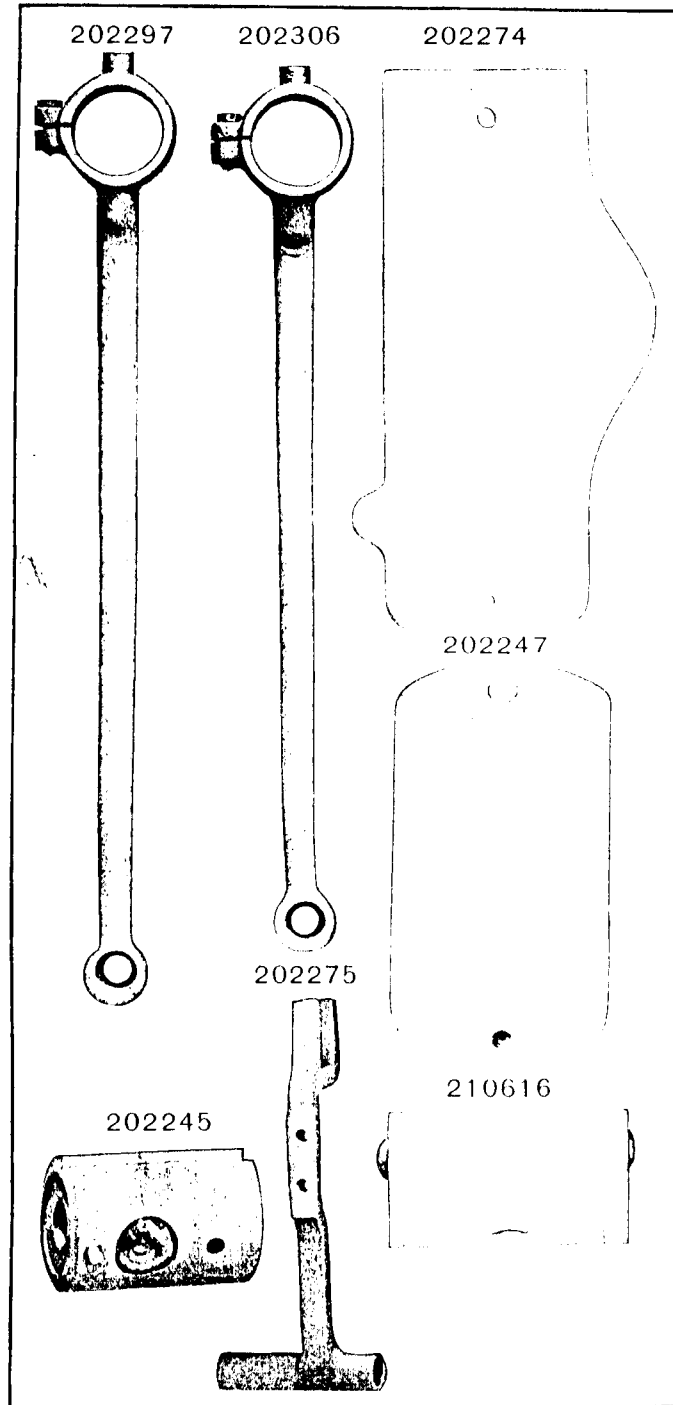

PLATE 10668 - FULL SIZE

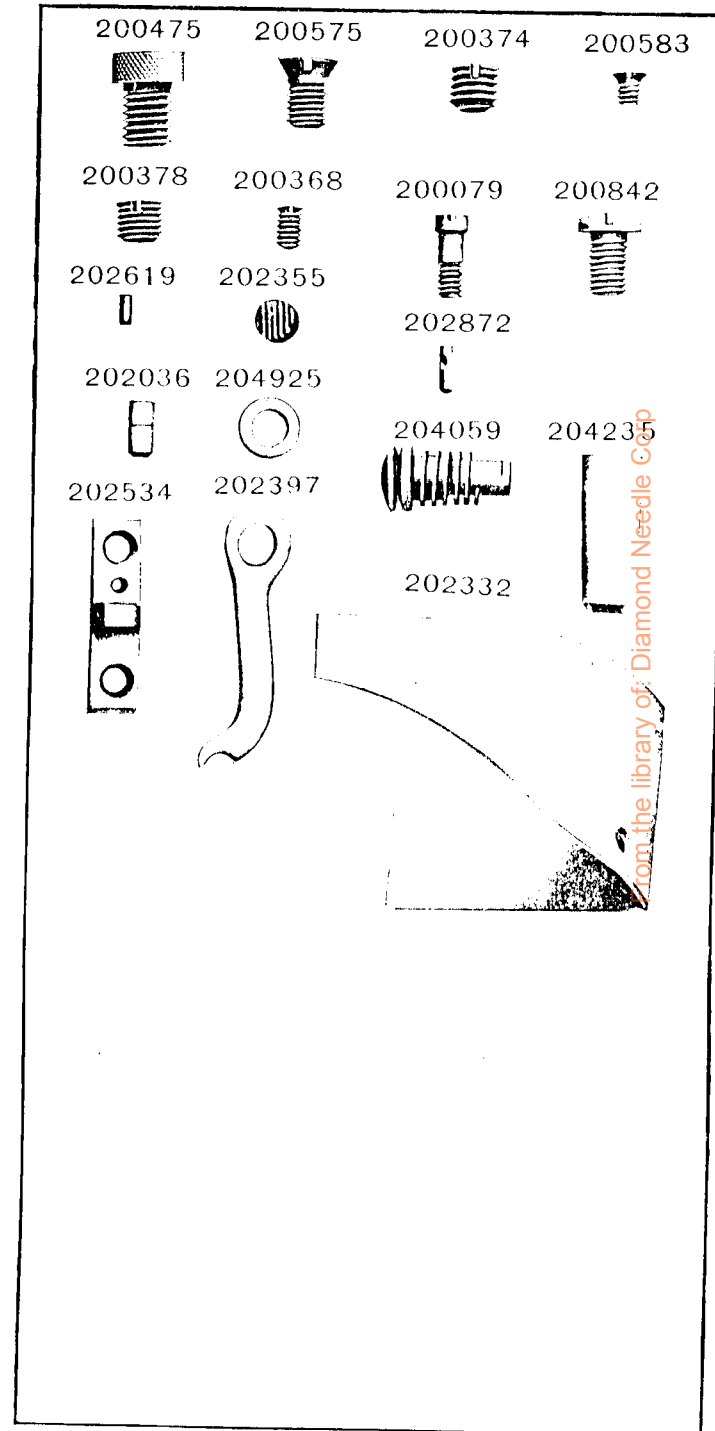

PLATE 10920 -FULL SIZE

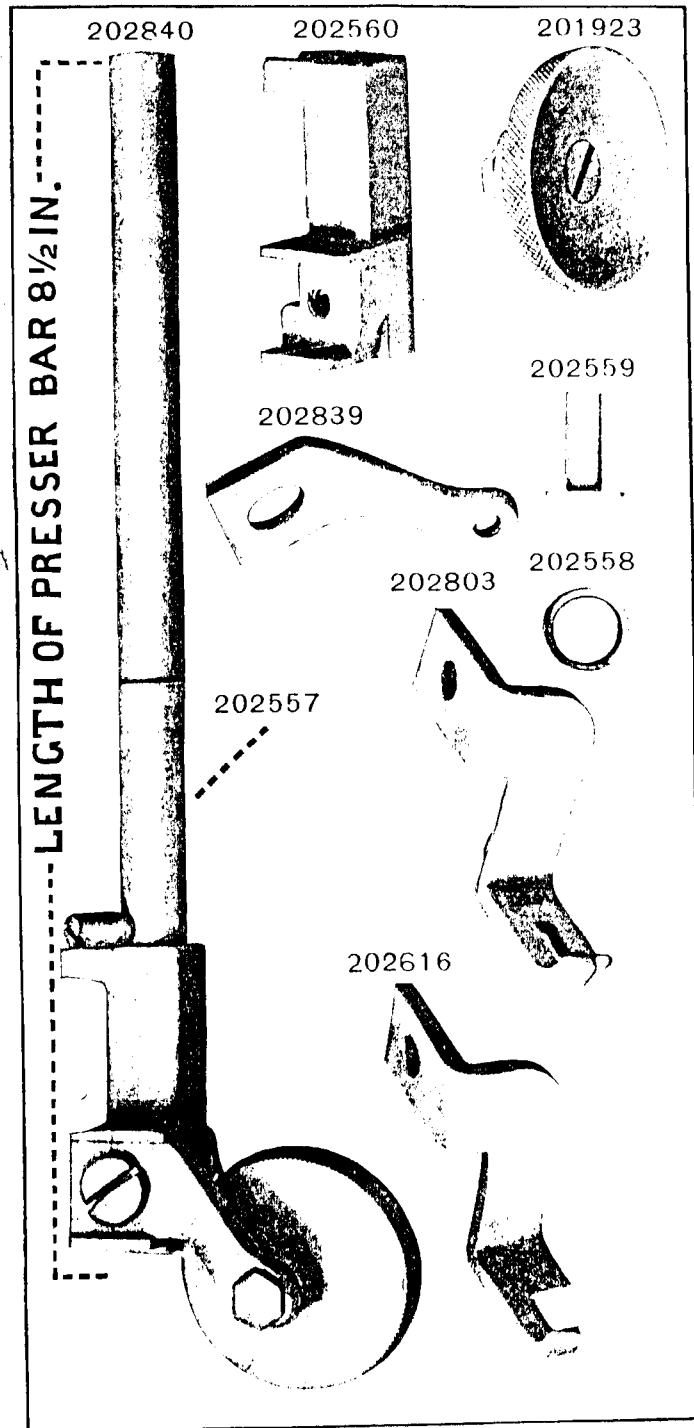

PLATE 10936 -ONE-FOURTH SIZE

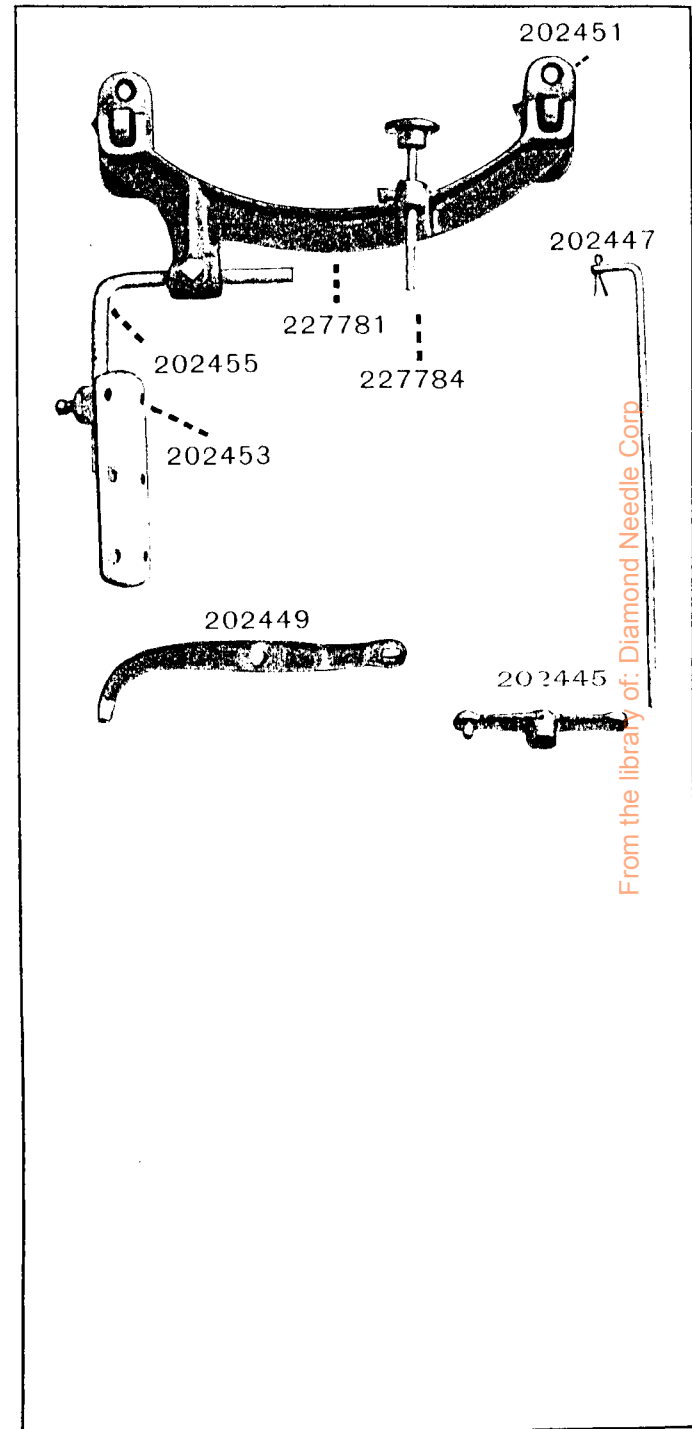

PLATE 10972-ONE-HALF SIZE

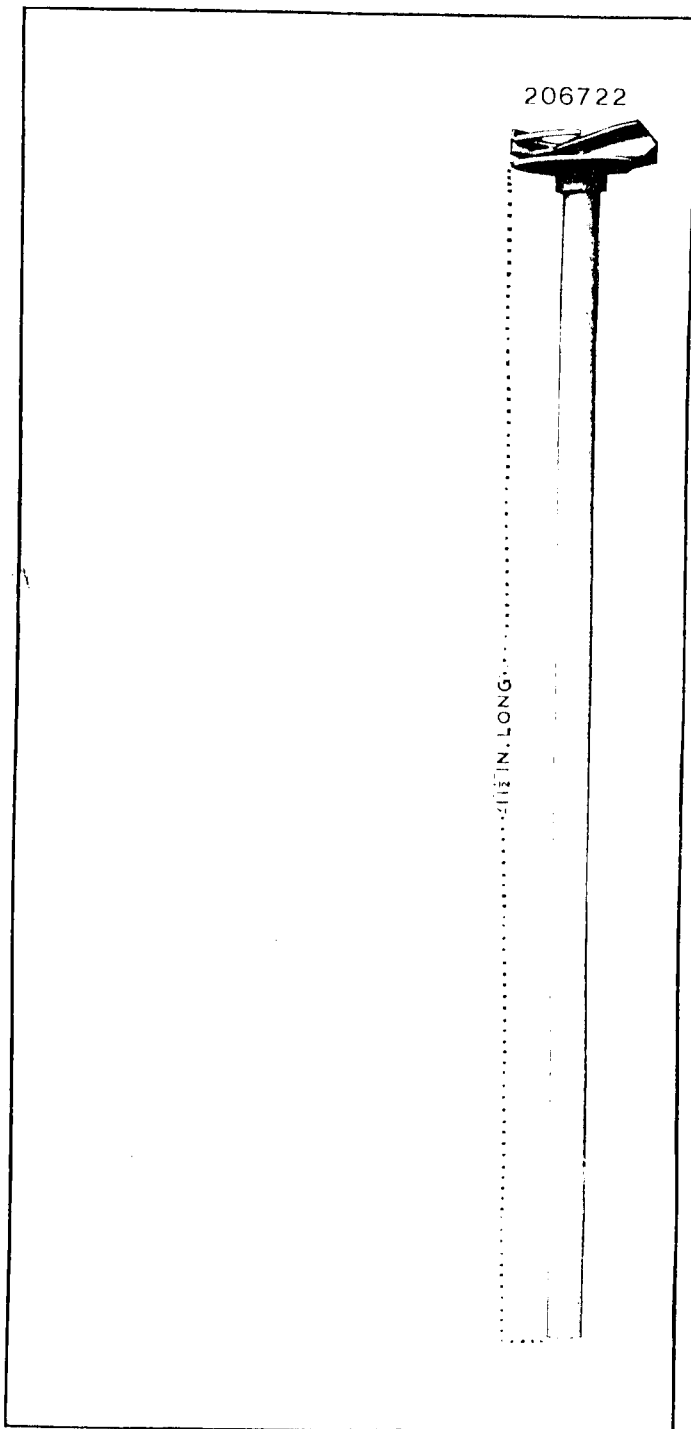
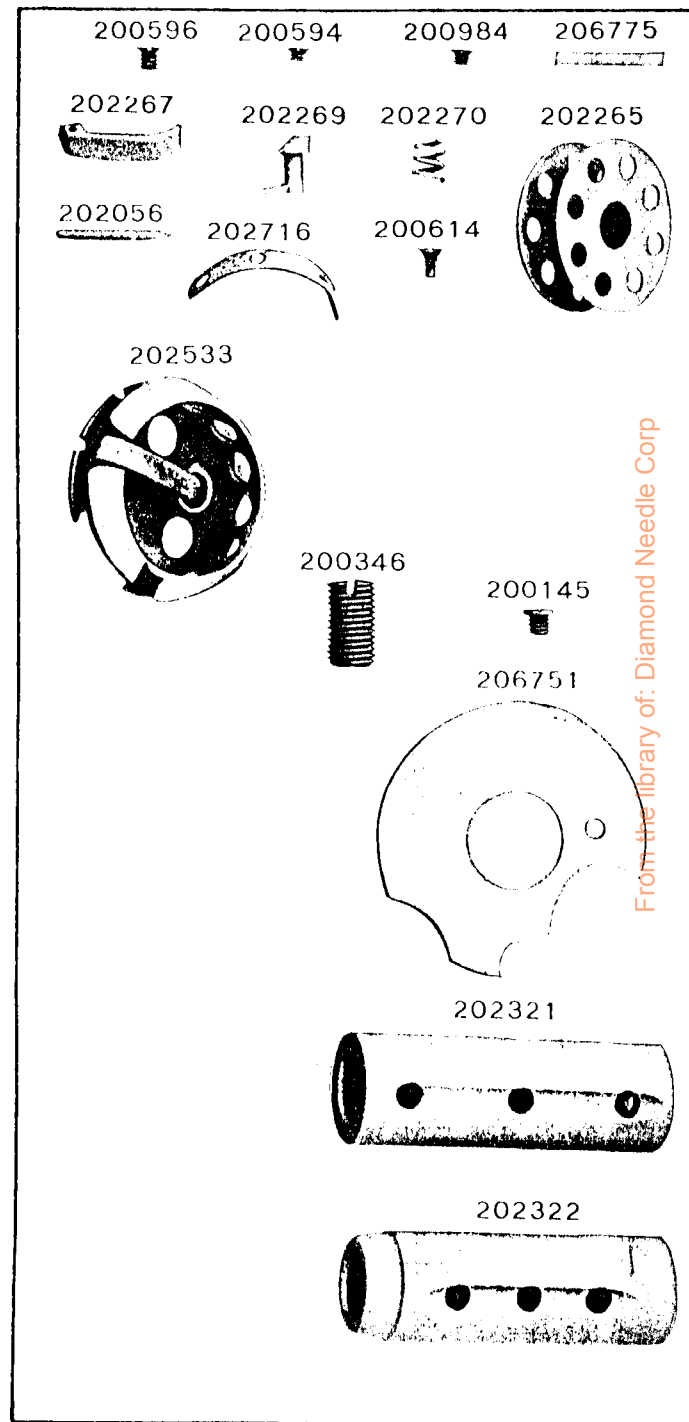

PLATE 11671-FULL SIZE



From the library of: Diamond Needle Corp

PLATE 12153—ONE-HALF SIZE

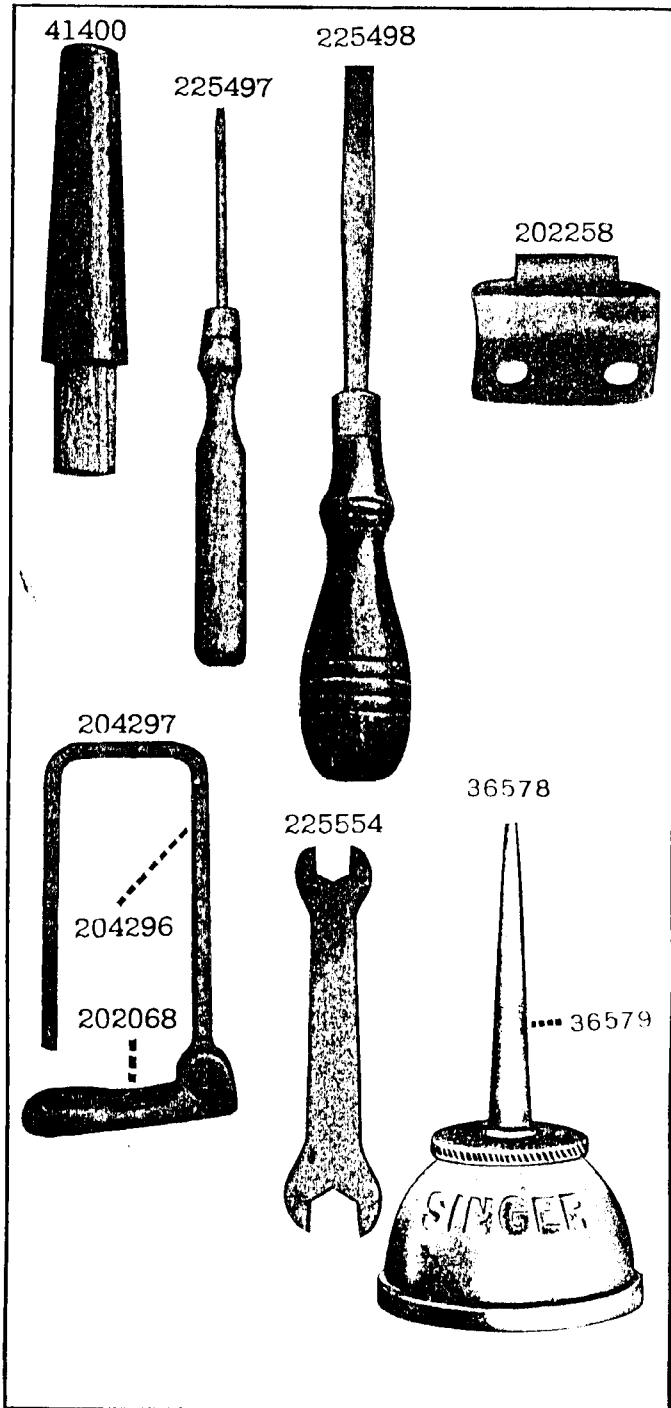
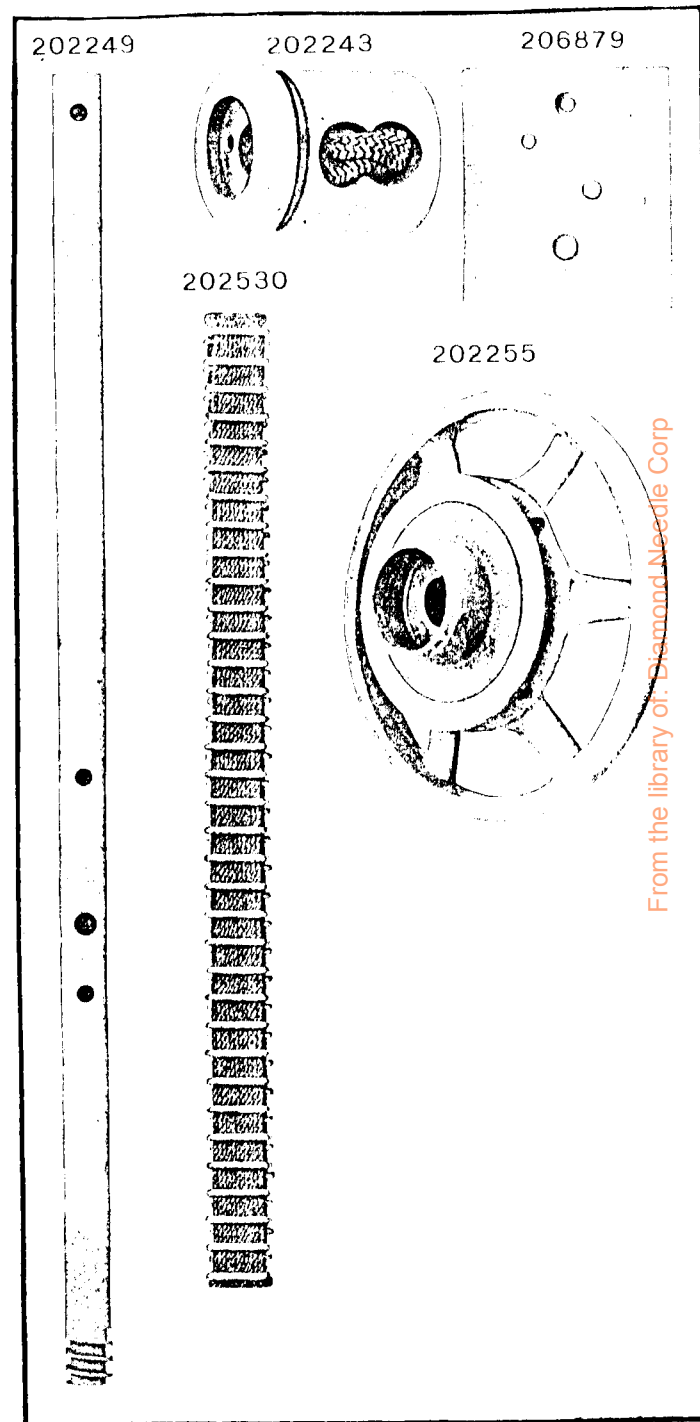

PLATE 13351—ONE-HALF SIZE



From the library of: Diamond Needle Corp

PLATE 13352—ONE-HALF SIZE

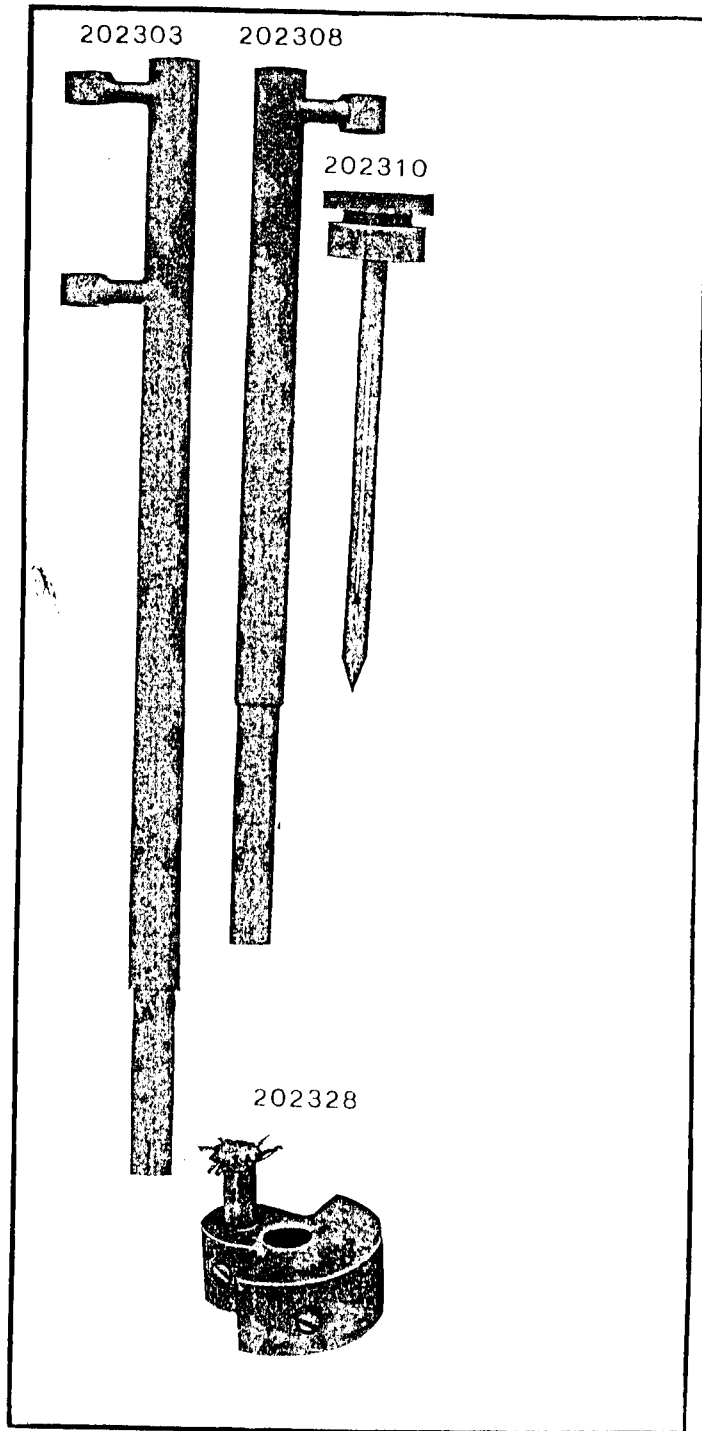

PLATE 13361—FULL SIZE

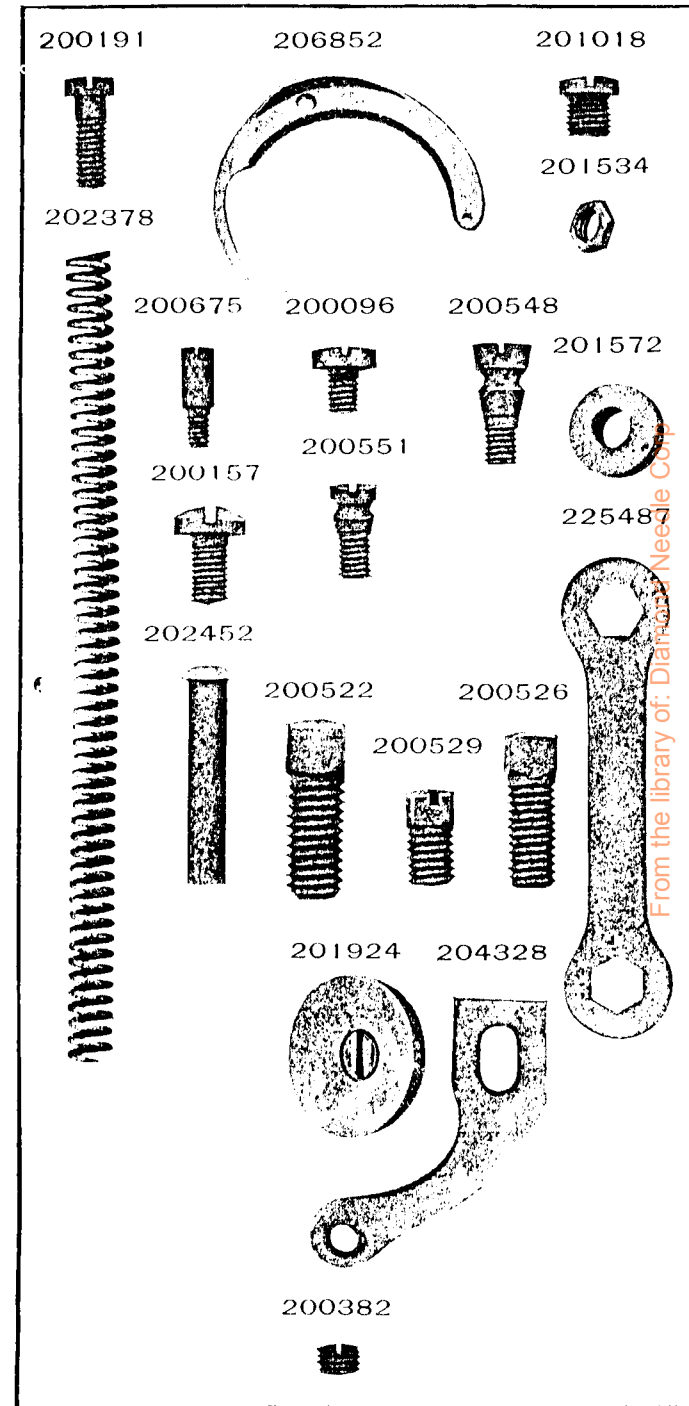
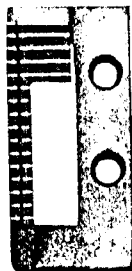

PLATE 13362-FULL SIZE

202283



202285



202813



203138

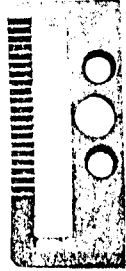

207051

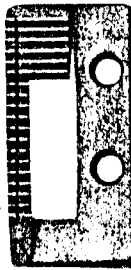

207052

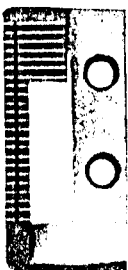

202819

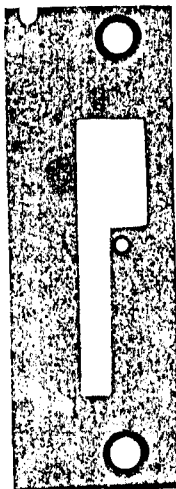

202820

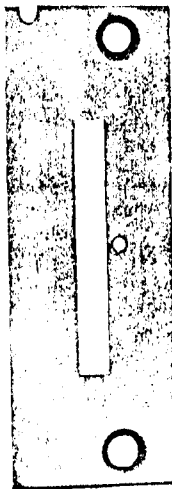

206798

